

PREVENTIVE MAINTENANCE POLICY FOR LINEAR CONSECUTIVE-K-OUT-OF-N: F SYSTEM

Alfonsus Julanto Endharta
Pusan National University

Won Young Yun

Hisashi Yamamoto
Tokyo Metropolitan University

(Received September 28, 2015; Revised August 16, 2016)

Abstract Linear consecutive- k -out-of- n : F systems are considered. It is assumed that the components are independent and the component failure times follow an exponential distribution with identical failure rate. It is also assumed that there are only two component states (working and failed) and we can know the component state at any time. If there is at least one minimal cut set consisting of one working component, the system will be preventively maintained after a certain time interval. If the system fails before reaching the preventive maintenance (PM) time, the failed components are replaced by the new ones. The optimal PM interval time which minimizes the expected cost rate is obtained. The performance of the proposed policy is evaluated by comparing the expected cost rate of the proposed policy with those of corrective maintenance (CM) and age PM policy.

Keywords: Maintenance, consecutive- k -out-of- n : F system, linear, condition-based maintenance

1. Introduction

In this paper, a preventive maintenance problem of a linear consecutive- k -out-of- n : F system is considered. Linear consecutive- k -out-of- n : F system is a multi-component system consists of n components which are arranged linearly. This system fails if there are k consecutive failed components in the system [7]. Consecutive- k -out-of- n : F systems are used commonly in the integrated circuits, microwave relay stations in telecommunications, oil pipeline system, vacuum system in accelerators, computer ring networks (k -loop), and spacecraft relay stations [7].

Previous studies on the consecutive- k -out-of- n : F systems mostly focused on how to calculate the exact system reliability or the lower bound of the system reliability. The system design problems were also studied in which the values of k and/or n are determined optimally. Yet, there are few research results in maintenance problems for consecutive- k -out-of- n : F systems. Bollinger and Salvia [2] built a recursive equation to calculate the reliability of a consecutive- k -out-of- n : F system. Lambiris and Papastavridis [8] proposed a model for the system reliabilities of linear and circular consecutive- k -out-of- n : F systems. Pekoz and Ross [9] simplified the model in Lambiris and Papastavridis [8]. Canfield and McCormick [3] proposed an asymptotic reliability model. Yun, Kim, and Yamamoto [11] proposed a modified formula to calculate the system reliability of a circular consecutive- k -out-of- n : F system and a method to find the optimal system design for the circular consecutive- k -out-of- n : F system with $(k-1)$ -step Markov dependence. Flynn and Chung [5] proposed a maintenance policy related to the critical component policies (CCP) for consecutive- k -out-of- n : F systems. The failed components are replaced only if the components are in the critical component set. They used a branch and bound algorithm to find the optimal CCP.

Zuo and Wu [13] studied an age replacement policy for k -out-of- n : F system and consecutive- k -out-of- n : F system. Yun, Kim, and Yamamoto [12] considered system design problems and age replacement policy for linear and circular consecutive- k -out-of- n : F systems with load sharing dependence. Endharta and Yun [4] developed a condition-based maintenance policy for linear consecutive- k -out-of- n : F systems and used simulation to get the optimal decision variable. Yun and Endharta [10] also used simulation for the two-dimensional systems (linear consecutive- (r, s) -out-of- (m, n) : F systems).

In this paper, we study a preventive maintenance problem for a linear consecutive- k -out-of- n : F system. A condition-based maintenance policy which has been developed in Yun and Endharta [10] is considered. If there is at least one minimal cut set with only one working component, preventive maintenance will be done after a certain time interval by replacing the failed components with the new ones. If the system fails before reaching the preventive maintenance time, the system will be maintained correctively at failure time by replacing the failed components with the new ones. We derive a mathematical formulation to find the expected cost rate. The optimal preventive maintenance interval (T_{PM}) is obtained by minimizing the expected cost rate. The policy is compared to the existing maintenance policies, such as corrective maintenance and age PM policies.

The paper is organized as follows. Section 2 shows the condition-based maintenance policy, including the assumption, notation, system failure distribution, and the model to estimate the expected cost rate. In Section 3, numerical examples for various system and cost parameters are done. Section 4 shows the comparison results among the condition-based, corrective, and age replacement policies. Section 5 concludes the paper.

2. Condition-Based Maintenance Policy

The preventive maintenance (PM) occurs at a time interval T_{PM} after a certain condition occurs. The condition is related to the system minimal cut set, which is a set of components in the system and if all components in the minimal cut set fails, the system will fail immediately. The proposed policy is that PM is done at a time interval T_{PM} after there is at least one minimal cut set consisting of only one working component. If the system fails before reaching the PM time after the condition is satisfied, the system is maintained correctively (CM). The illustration of the condition-based maintenance (CBM) policy is shown in Figure 1. The time that there is at least one minimal cut set consisting of only one working component is represented by t^{ow} and the time of system failure is t^{SF} . We assume that we can know when the event of t^{ow} occurs.

We define a random variable $\tau^{cm} = t^{SF} - t^{ow}$, representing the time difference between t^{ow} and t^{SF} . Consider the renewal time is the time when the maintenance is done, which is the time of preventive maintenance before system failure or the time of maintenance at the system failure. If $\tau^{cm} > T_{PM}$, the renewal time is ended by PM and the system is maintained preventively (see Figure 1.a). Otherwise, if $\tau^{cm} < T_{PM}$, the renewal time is ended by CM and the system is maintained correctively (see Figure 1.b).

2.1. Assumptions and notation

Assumptions:

1. Components and system have two states: working and failed.
2. Components states can be monitored continuously.
3. Replacement times are negligible.
4. Component failure times are independent, identical and following an exponential distribution with failure rate λ .

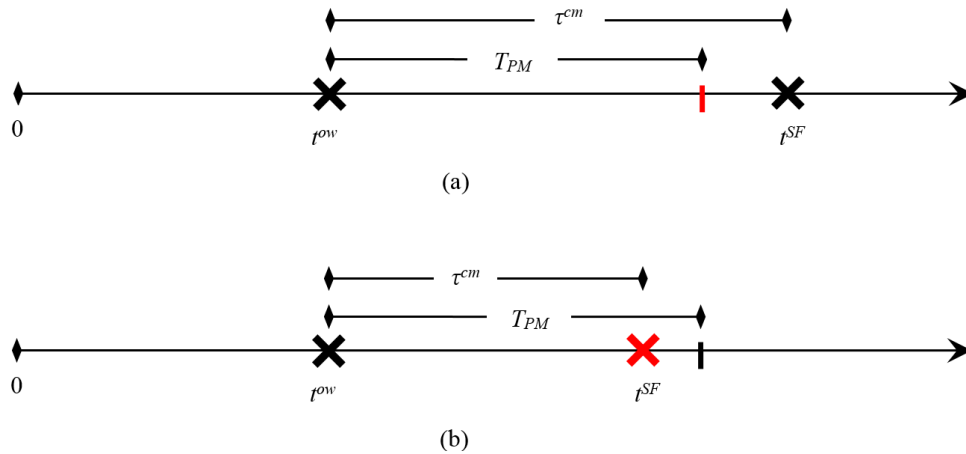

Figure 1: Illustration of the condition-based maintenance policy.(a) PM occurs and (b) CM occurs

Notation:

n	Number of components in the system
k	Minimum number of consecutive failed components for the system failure
λ	Failure rate of working component
α_{ji}	Sum of failure rates of working components in step i in path j
β_{ji}	Failure rate of a failed component in step i in path j
w_{ji}	Number of working components in step i in path j
s_j^{ow}	Step when there is one minimal cut set with one working component in path j
t_j^{ow}	Time when there is one minimal cut set with one working component in path j
t^{ow}	Time when there is one minimal cut set with one working component
τ_j^{cm}	Time between t_j^{ow} and the system failure in path j
τ_j^{pm}	Time between t_j^{ow} and PM time in path j
N_j^{ow}	Number of component failures at step s_j^{ow} in path j
$N_j^{T_{PM}}$	Number of component failures at PM time in path j
N^{ow}	Number of component failures at step s^{ow}
N^{SF}	Number of component failures at system failure time
$N^{T_{PM}}$	Number of component failures at PM time
π_j	Probability that the system failure follows path j
T_j	Time between t_j^{ow} and renewal time in path j
$f_j(t), F_j(t)$	PDF and CDF of T_j
N_j	Number of steps until the system failure in path j
P	Number of paths
T_{PM}	Time interval between time when there is one minimal cut set with one working component and PM time
$F(T_{PM})$	Probability that the system will fails before PM time at T_{PM}
$E[N(T_{PM})]$	Expected number of component failures at the renewal time
$E[T(T_{PM})]$	Expected system renewal time
EC_x	Expected cost rate for condition-based maintenance ($x = Cr$), for CM ($x = CM$), for age PM ($x = A$)
IP	Improvement percentage

2.2. System failure distribution

We consider a binary state: 1 for working state and 0 for failed state. At the beginning, all n identical components are working so that the system state vector is $(1, 1, \dots, 1)$. The component fails one by one and the component failure sequences are constructed. These sequences from the beginning state (all working component states) to the system failure state, which consists of at least k consecutive failed component, are called the system failure paths. In order to estimate the system failure probability, we consider paths from the system state in the beginning of time and the system failure state. There are at most $n!$ paths to the system failure for a consecutive- k -out-of- n : F system; thus, this system has at most $n!$ paths. In order to obtain the system failure time distribution, a lemma is introduced.

Lemma 2.1. Let Y_1, Y_2, \dots, Y_m be exponentially distributed random variables with failure rates h_1, h_2, \dots, h_m , and let $Z = \min(Y_1, Y_2, \dots, Y_m)$. Then Z is also exponentially distributed with failure rate $\sum h_i$ and $\Pr\{Z = Y_i\} = h_i / \sum h_i$ (Bollinger and Salvia [2]).

Lemma 2.1 gives the probability of selecting the component which will fail in step i among the working components. Suppose the sum of failure rates of working components after i th failure is denoted as α_{ji} , the failure rate of the i th failed component in path j is denoted by β_{ji} , and the number of steps until the system failure in path j is N_j . Define T_j as the time to complete path j and T as the time to system failure. The probability that the system follows path j , which is represented as π_j , is $\Pr\{T = T_j\}$. Suppose X_i is the time between $(i-1)$ th failure and i th failure in the system and X_{ji} is the time between $(i-1)$ th failure and i th failure in path j ,

$$\begin{aligned} \pi_j &= \Pr \{X_1 = X_{j1}, X_2 = X_{j2}, \dots, X_{N_j} = X_{jN_j}\} \\ &= \Pr \{X_1 = X_{j1}\} \cdot \prod_{i=2}^{N_j} \Pr \{X_i = X_{ji} | X_1 = X_{j1}, X_2 = X_{j2}, \dots, X_{j,i-1} = X_{j,i-1}\}. \end{aligned}$$

From Lemma 2.1 , it can be verified that

$$\Pr \{X_i = X_{ji} | X_1 = X_{j1}, X_2 = X_{j2}, \dots, X_{j,i-1} = X_{j,i-1}\} = \frac{\beta_{ji}}{\alpha_{ji}}.$$

Thus, the probability that the system follows path j is

$$\pi_j = \prod_{i=1}^{N_j-1} \frac{\beta_{ji}}{\alpha_{ji}}. \tag{2.1}$$

Since the component failure times are independent, identical, and following an exponential distribution with failure rate λ and w_{ji} represents the number of working components in step i in path j , we can conclude that the component failure rates at all steps are same.

$$\beta_{1i} = \beta_{2i} = \dots = \beta_{Pi} = \lambda \text{ for all } i \text{ and } \alpha_{ji} = w_{ji}\lambda \text{ for all } i, j.$$

Thus, substituting above equations into (2.1), the probability that the system failure occurs from path j becomes

$$\pi_j = \prod_{i=1}^{N_j-1} \frac{1}{w_{ji}}. \tag{2.2}$$

Laplace transform of the distribution of X_{ji} is

$$f_{X_{ji}}^e(s) = \frac{\alpha_{ji}}{\alpha_{ji} + s}$$

thus, Laplace transform of the distribution of T_j is

$$f_j^e(s) = \prod_{i=0}^{N_j-1} \frac{\alpha_{ji}}{\alpha_{ji}s}$$

By using partial fraction, we can get

$$f_j^e(s) = \sum_{i=0}^{N_j-1} A_{ji} \frac{\alpha_{ji}}{\alpha_{ji} + s} \text{ where } A_{ji} = \prod_{m=0, m \neq i}^{N_j-1} \frac{\alpha_{jm}}{\alpha_{jm} - \alpha_{ji}} \text{ for } i = 0, 1, \dots, N_j - 1.$$

Then, by inverting the Laplace transform and the integral function, we can obtain the system failure probability in path j as follows

$$F_j(t) = 1 - \sum_{i=0}^{N_j-1} A_{ji} e^{-\alpha_{ji}t} \text{ for } j = 1, 2, \dots, P \tag{2.3}$$

where $A_{ji} = \prod_{m=s_j^{ow}, m \neq i}^{N_j-1} \frac{w_{jm}}{w_{jm} - w_{ji}}$ for $i = 0, 1, 2, \dots, N_j - 1$.

Distribution of the system failure is a mixture of the distributions of T_1, T_2, \dots, T_P [2]. Thus, the system failure probability can be estimated as follows,

$$\begin{aligned} F(t) &= \sum_{j=1}^P \pi_j F_j(t) \\ &= \sum_{j=1}^P \pi_j \left(1 - \sum_{i=s_j^{ow}}^{N_j-1} A_{ji} e^{-w_{ji}\lambda t} \right) \\ &= 1 - \sum_{j=1}^P \sum_{i=s_j^{ow}}^{N_j-1} \pi_j A_{ji} e^{-w_{ji}\lambda t} \end{aligned} \tag{2.4}$$

where $\pi_j = \prod_{i=1}^{N_j-1} \frac{1}{w_{ji}}$ and $A_{ji} = \prod_{m=s_j^{ow}, m \neq i}^{N_j-1} \frac{w_{jm}}{w_{jm} - w_{ji}}$ for $i = 0, 1, 2, \dots, N_j - 1$.

For example, for a linear consecutive-3-out-of-4: F system there are 24 paths to the system failure and the details can be seen in Table 1. Based on Table 1, the steps where there are minimal cut sets with only one working component are step 2 and 3 ($s_j^{ow} = 2, 3$) and the system may fail at step 3 and 4 ($N_j = 4, 5$). In Path 5, 6, 19, and 20, in step 4 two minimal cut sets have one working component, although in step 2, all two minimal cut sets have two working components. The necessary terms for each path, such as π_j, N_j , and s_j^{ow} are shown in Table 2.

The renewal time in path j can be derived as follows

$$T_j = t_j^{ow} + \min(\tau_j^{cm}, \tau_j^{pm}). \tag{2.5}$$

Thus, the expected system renewal time can be estimated as follows

$$\begin{aligned} E[T(T_{PM})] &= E[t^{ow}] + \int_0^{T_{PM}} t \cdot d\Pr\{T \leq t\} + T_{PM} \Pr\{T > t\} \\ &= E[t^{ow}] + \int_0^{T_{PM}} t \cdot dF\{t\} + T_{PM} (1 - F(T_{PM})) \\ &= E[t^{ow}] + \int_0^{T_{PM}} \sum_{j=1}^P \sum_{i=s_j^{ow}}^{N_j-1} \pi_j A_{ji} \alpha_{ji} t e^{-\alpha_{ji}\lambda t} + T_{PM} \sum_{j=1}^P \sum_{i=s_j^{ow}}^{N_j-1} \pi_j A_{ji} \alpha_{ji} e^{-\alpha_{ji}\lambda T_{PM}} \end{aligned}$$

Table 1: Paths to system failure for a linear consecutive-3-out-of-4: F system

Path <i>j</i>	Step <i>i</i>				
	0	1	2	3	4
1	(1, 1, 1, 1)	- (0, 1, 1, 1)	- (0, 0, 1, 1)*	- (0, 0, 0, 1)	
2	(1, 1, 1, 1)	- (0, 1, 1, 1)	- (0, 0, 1, 1)*	- (0, 0, 1, 0)	- (0, 0, 0, 0)
3	(1, 1, 1, 1)	- (0, 1, 1, 1)	- (0, 1, 0, 1)*	- (0, 0, 0, 1)	
4	(1, 1, 1, 1)	- (0, 1, 1, 1)	- (0, 1, 0, 1)*	- (0, 1, 0, 0)	- (0, 0, 0, 0)
5	(1, 1, 1, 1)	- (0, 1, 1, 1)	- (0, 1, 1, 0)	- (0, 0, 1, 0)*	- (0, 0, 0, 0)
6	(1, 1, 1, 1)	- (0, 1, 1, 1)	- (0, 1, 1, 0)	- (0, 1, 0, 0)*	- (0, 0, 0, 0)
7	(1, 1, 1, 1)	- (1, 0, 1, 1)	- (0, 0, 1, 1)*	- (0, 0, 0, 1)	
8	(1, 1, 1, 1)	- (1, 0, 1, 1)	- (0, 0, 1, 1)*	- (0, 0, 1, 0)	- (0, 0, 0, 0)
9	(1, 1, 1, 1)	- (1, 0, 1, 1)	- (1, 0, 0, 1)*	- (0, 0, 0, 1)	
10	(1, 1, 1, 1)	- (1, 0, 1, 1)	- (1, 0, 0, 1)*	- (1, 0, 0, 0)	
11	(1, 1, 1, 1)	- (1, 0, 1, 1)	- (1, 0, 1, 0)*	- (0, 0, 1, 0)	- (0, 0, 0, 0)
12	(1, 1, 1, 1)	- (1, 0, 1, 1)	- (1, 0, 1, 0)*	- (1, 0, 0, 0)	
13	(1, 1, 1, 1)	- (1, 1, 0, 1)	- (0, 1, 0, 1)*	- (0, 0, 0, 1)	
14	(1, 1, 1, 1)	- (1, 1, 0, 1)	- (0, 1, 0, 1)*	- (0, 1, 0, 0)	- (0, 0, 0, 0)
15	(1, 1, 1, 1)	- (1, 1, 0, 1)	- (1, 0, 0, 1)*	- (0, 0, 0, 1)	
16	(1, 1, 1, 1)	- (1, 1, 0, 1)	- (1, 0, 0, 1)*	- (1, 0, 0, 0)	
17	(1, 1, 1, 1)	- (1, 1, 0, 1)	- (1, 1, 0, 0)*	- (0, 1, 0, 0)	- (0, 0, 0, 0)
18	(1, 1, 1, 1)	- (1, 1, 0, 1)	- (1, 1, 0, 0)*	- (1, 0, 0, 0)	
19	(1, 1, 1, 1)	- (1, 1, 1, 0)	- (0, 1, 1, 0)	- (0, 0, 1, 0)*	- (0, 0, 0, 0)
20	(1, 1, 1, 1)	- (1, 1, 1, 0)	- (0, 1, 1, 0)	- (0, 1, 0, 0)*	- (0, 0, 0, 0)
21	(1, 1, 1, 1)	- (1, 1, 1, 0)	- (1, 0, 1, 0)*	- (0, 0, 1, 0)	- (0, 0, 0, 0)
22	(1, 1, 1, 1)	- (1, 1, 1, 0)	- (1, 0, 1, 0)*	- (1, 0, 0, 0)	
23	(1, 1, 1, 1)	- (1, 1, 1, 0)	- (1, 1, 0, 0)*	- (0, 1, 0, 0)	- (0, 0, 0, 0)
24	(1, 1, 1, 1)	- (1, 1, 1, 0)	- (1, 1, 0, 0)*	- (1, 0, 0, 0)	

*: state s_j^{ow} when there is at least one minimal cut set with one working component

where $E[t^{ow}] = \sum_{j=1}^P \sum_{i=0}^{s_j^{ow}-1} \frac{\pi_j}{w_j \lambda}$, $\pi_j = \prod_{i=1}^{N_j-1} \frac{1}{w_{ji}}$, and $A_{ji} = \prod_{m=s_j^{ow}, m \neq i}^{N_j-1} \frac{w_{jm}}{w_{jm}-w_{ji}}$ for $i = 0, 1, 2, \dots, N_j - 1$.

Define N^{ow} as the number of component failures at step s^{ow} , N_j^{ow} as the number of component failures at step s_j^{ow} in path j , N^{SF} as the number of component failures when the system fails, N^{TPM} as the number of component failures at PM time and N_j^{TPM} as the number of component failures at PM time in path j . The components are replaced at maintenance time and the expected number of component failures includes the number of component failures at s^{ow} and the expected additional component failures until system failure and the expected additional component failures until maintenance time T_{PM} ,

$$\begin{aligned}
 E[N(T_{PM})] &= E[N^{OW}] + E[N^{SF}] + E[N^{TPM}] \\
 &= \sum_{j=1}^P \pi_j N_j^{ow} + \sum_{j=1}^P \pi_j N_j F_j(T_{PM}) + \sum_{j=1}^P \pi_j E[N_j^{TPM}] \\
 &= \sum_{j=1}^P \pi_j (N_j^{ow} + N_j F_j(T_{PM}) + E[N_j^{TPM}]) \tag{2.6}
 \end{aligned}$$

Table 2: $\pi_j, N_j,$ and s_j^{ow} for a linear consecutive-3-out-of-4: F system

Path j	N_j	π_j	s_j^{ow}	Path j	N_j	π_j	s_j^{ow}
1	4	1/24	3	13	4	1/24	3
2	5	1/24	3	14	5	1/24	3
3	4	1/24	3	15	4	1/24	3
4	5	1/24	3	16	4	1/24	3
5	5	1/24	4	17	5	1/24	3
6	5	1/24	4	18	4	1/24	3
7	4	1/24	3	19	5	1/24	4
8	5	1/24	3	20	5	1/24	4
9	4	1/24	3	21	5	1/24	3
10	4	1/24	3	22	4	1/24	3
11	5	1/24	3	23	5	1/24	3
12	4	1/24	3	24	4	1/24	3

where

$$F_j(t) = 1 - \sum_{i=s_j^{ow}}^{N_j-1} A_{ji} e^{-\alpha_{ji}t} \text{ and } E[N_j^{TPM}] = \sum_{i=s_j^{ow}}^{N_j-1} \sum_{m=s_j^{ow}}^{i-1} \frac{i A_{jm} \alpha_{jm}}{\alpha_{ji} - \alpha_{jm}} (e^{-\alpha_{ji}T_{PM}} - e^{-\alpha_{jm}T_{PM}}).$$

2.3. Expected cost rate

Suppose we replace all components, both failed and working components at maintenance times. Thus, the expected cost rates with the proposed maintenance policy $EC_{Cr}(T_{PM})$ can be estimated as follows.

$$EC_{Cr}(T_{PM}) = \frac{c_{CM}F(T_{PM}) + c_{PM}(1 - F(T_{PM})) + c_R E[N^{TPM}]}{E[T(T_{PM})]} \tag{2.7}$$

where

$$F(t) = 1 - \sum_{j=1}^P \sum_{i=s_j^{ow}}^{N_j-1} \pi_j A_{ji} e^{-w_{ji}\lambda t}, E[N(T_{PM})] = \sum_{j=1}^P \pi_j (N_j^{ow} + N_j F_j(T_{PM}) + E[N_j^{TPM}]),$$

$$E[T(T_{PM})] = E[t^{ow}] + \int_0^{T_{PM}} \sum_{j=1}^P \sum_{i=s_j^{ow}}^{N_j-1} \pi_j A_{ji} \alpha_{ji} t e^{-\alpha_{ji}\lambda t} + T_{PM} \sum_{j=1}^P \sum_{i=s_j^{ow}}^{N_j-1} \pi_j A_{ji} \alpha_{ji} e^{-\alpha_{ji}\lambda T_{PM}}.$$

The optimum maintenance interval T_{PM}^* minimizing the expected cost rate in (2.7) can be get by differentiating $EC_{PM}(T_{PM})$ in (2.7) with respect to T_{PM} and setting it equal to zero,

$$\frac{dEC(T_{PM})}{dT_{PM}} = 0.$$

3. Numerical Examples

In this section, numerical examples are studied. Different values of system and cost parameters are considered in the experimentation in order to show the effect of the corresponding parameters on the optimal T_{PM}^* . The optimal T_{PM}^* is obtained by enumeration.

The effects of the system parameters, such as system size and the failure rate of the component are studied. There are 16 cases which are studied: four component failure rates and four system sizes as shown in Table 3. For this experiment, the cost parameters are set as $c_{CM} = 2, c_{PM} = 1,$ and $c_R = 0.01.$

Table 3: Numerical examples for various system parameters

λ	k	n	$E[N]$	$E[T]$	EC_{Cr}	T_{PM}^*
0.01	3	4	3.50	158.3333	0.0129	∞
		7	4.54	97.6190	0.0210	∞
	5	6	4.40	115.0000	0.0091	0
		8	5.11	94.8810	0.0111	0
0.05	3	4	3.50	31.6667	0.0643	∞
		7	4.54	19.5238	0.1048	∞
	5	6	4.40	23.0000	0.0454	0
		8	5.11	18.9762	0.0554	0
0.1	3	4	3.50	15.8333	0.1285	∞
		7	4.54	9.7619	0.2095	∞
	5	6	4.40	11.5000	0.0908	0
		8	5.11	9.4881	0.1108	0
0.5	3	4	3.50	3.1667	0.6426	∞
		7	4.54	1.9524	1.0477	∞
	5	6	4.40	2.3000	0.4539	0
		8	5.11	1.8976	0.5539	0

In this experiment the effects of three cost parameters to the expected cost rate are studied, such as the cost of CM, the cost of PM, and the replacement cost. We studied 28 cases on a linear consecutive-5-out-of-6: F system with component failure rate $\lambda = 0.01$ and the cost of PM $c_{PM} = 1$ as shown in Table 4.

In Table 3 and 4, $T_{PM}^* = 0$ means that PM should be done immediately after there is a minimal cut set with only one working component. $T_{PM}^* = \infty$ means that CM is more preferred and the system should be replaced after the system fails. Table 3 shows that as the number of components n increases, the optimal T_{PM}^* increases. Table 4 shows that as the CM cost increases, the optimal T_{PM}^* decreases. This means that PM is more preferred because the CM cost is expensive and we should replace preventively. While the component replacement cost c_R increases, the optimal T_{PM}^* increases because the total replacement cost is less.

4. Comparison among CM, Age PM and CBM

In this section, the performance of the condition-based maintenance policy is studied and the expected cost rates from condition-based maintenance policy are compared to the expected cost rates from CM and age PM policies. CM policy is the basic maintenance policy in which the system is maintained if and only if the system fails. Age PM is one of preventive maintenances in which the system is maintained preventively after certain time interval. If the system fails before reaching the preventive time point, the system is maintained correctively at system failure.

The expected cost rate when the system is maintained only at system failure time,

Table 4: Numerical examples for various cost parameters

c_{CM}/c_{PM}	c_R	$E[N]$	$E[T]$	EC_{Cr}	T_{PM}^*
2	0.01	4.40	115.0000	0.0091	0
	0.05	4.40	115.0000	0.0106	0
	0.1	5.67	211.6667	0.0121	∞
	0.5	5.67	211.6667	0.0121	∞
3	0.01	4.40	115.0000	0.0091	0
	0.05	4.40	115.0000	0.0106	0
	0.1	4.40	115.0000	0.0125	0
	0.5	5.67	211.6667	0.0276	∞
4	0.01	4.40	115.0000	0.0091	0
	0.05	4.40	115.0000	0.0106	0
	0.1	4.40	115.0000	0.0125	0
	0.5	4.40	115.0000	0.0278	0
5	0.01	4.40	115.0000	0.0091	0
	0.05	4.40	115.0000	0.0106	0
	0.1	4.40	115.0000	0.0125	0
	0.5	4.40	115.0000	0.0278	0
6	0.01	4.40	115.0000	0.0091	0
	0.05	4.40	115.0000	0.0106	0
	0.1	4.40	115.0000	0.0125	0
	0.5	4.40	115.0000	0.0278	0
7	0.01	4.40	115.0000	0.0091	0
	0.05	4.40	115.0000	0.0106	0
	0.1	4.40	115.0000	0.0125	0
	0.5	4.40	115.0000	0.0278	0
8	0.01	4.40	115.0000	0.0091	0
	0.05	4.40	115.0000	0.0106	0
	0.1	4.40	115.0000	0.0125	0
	0.5	4.40	115.0000	0.0278	0

EC_{CM} , can be estimated by modifying some terms,

$$EC_{CM} = \frac{c_{CM} + c_R \sum_{j=1}^P \pi_j N_j}{\sum_{j=1}^P \pi_j \sum_{i=1}^{N_j-1} \frac{1}{w_{ji}\lambda}}. \tag{4.1}$$

To obtain the expected cost rate of age PM policy, s_j^{ow} is changed equal to 0 because we cannot monitor the system and the PM interval starts from the beginning of the system operation. By modifying (2.7), the expected cost rate for age PM with PM interval T_A , $EC_A(T_A)$, can be estimated as follows

$$EC_A(T_A) = \frac{c_{CM}F(T_A) + c_{PM}(1 - F(T_A)) + c_R \sum_{j=1}^P \pi_j (N_j F_j(T_A) + E[N_j^{TA}])}{E[T(T_A)]} \tag{4.2}$$

where

$$F(t) = 1 - \sum_{j=1}^P \sum_{i=0}^{N_j-1} \pi_j A_{ji} e^{-w_{ji}\lambda t}, F_j(t) = 1 - \sum_{i=0}^{N_j-1} A_{ji} e^{-\alpha_{ji}t},$$

$$E[N_j^{T_A}] = \sum_{i=0}^{N_j-1} \sum_{m=0}^{i-1} \frac{i A_{jm} \alpha_{jm}}{\alpha_{ji} - \alpha_{jm}} (e^{-\alpha_{ji}T_A} - e^{-\alpha_{jm}T_A}) \text{ and}$$

$$E[T(T_A)] = \int_0^{T_A} \sum_{j=1}^P \sum_{i=0}^{N_j-1} \pi_j A_{ji} \alpha_{ji} t e^{-\alpha_{ji}\lambda t} + T_A \sum_{j=1}^P \sum_{i=0}^{N_j-1} \pi_j A_{ji} \alpha_{ji} e^{-\alpha_{ji}\lambda T_A}.$$

We define the improvement percentage (*IP*) as the cost reduction between expected cost rates from two policies as follows:

$$IP_{Cr,CM} = \frac{EC_{CM} - EC_{Cr}(T_{PM}^*)}{EC_{Cr}(T_{PM}^*)} \times 100\% \text{ and} \tag{4.3}$$

$$IP_{Cr,A} = \frac{EC_A(T_A^*) - EC_{Cr}(T_{PM}^*)}{EC_{Cr}(T_{PM}^*)} \times 100\%. \tag{4.4}$$

where EC_{CM} is the expected cost rate with CM policy and $EC_A(T_A^*)$ is the expected cost rate with age PM policy.

Table 5 shows the expected cost rates if CM and age PM are considered with $c_{CM} = 2$, $c_{PM} = 1$, and $c_R = 0.01$. The improvement percentage values are positive and it means that the proposed CBM policy outperforms CM and age PM policies for the considered system size and component failure rate in Table 5. The expected cost can be reduced by at most 7% from CM and age PM policies.

Table 5: Expected cost rates for various system parameters (CM and age PM)

λ	k	n	Corrective replacement				Age replacement				
			$E[N]$	$E[T]$	EC_{CM}	$IP_{Cr,CM}$	$E[N]$	$E[T]$	EC_A	T_A^*	$IP_{Cr,A}$
0.01	3	4	3.5	158.33	0.013	0.00	3.5	158.33	0.013	∞	0.00
		7	4.5	97.62	0.021	0.00	4.5	97.62	0.021	∞	0.00
	5	6	5.7	211.67	0.010	6.59	5.5	199.37	0.010	346.2	6.59
		8	6.9	178.33	0.012	4.50	6.9	178.33	0.012	∞	4.50
0.05	3	4	3.5	31.67	0.064	0.00	3.5	31.67	0.064	∞	0.00
		7	4.5	19.52	0.105	0.00	4.5	19.52	0.105	∞	0.00
	5	6	5.7	42.33	0.049	7.05	5.5	39.87	0.049	69.2	6.83
		8	6.9	35.67	0.058	4.69	6.9	35.67	0.058	∞	4.69
0.1	3	4	3.5	15.83	0.129	0.00	3.5	15.83	0.129	∞	0.00
		7	4.5	9.76	0.210	0.00	4.5	9.76	0.210	∞	0.00
	5	6	5.7	21.17	0.097	7.05	5.5	19.93	0.097	34.6	6.83
		8	6.9	17.83	0.116	4.69	6.9	17.83	0.116	∞	4.69
0.5	3	4	3.5	3.17	0.643	0.00	3.5	3.17	0.643	∞	0.00
		7	4.5	1.95	1.048	0.00	4.5	1.95	1.048	∞	0.00
	5	6	5.7	4.23	0.486	7.03	5.5	3.98	0.485	6.9	6.90
		8	6.9	3.57	0.580	4.71	6.9	3.57	0.580	∞	4.71

Table 6 shows the expected cost rates for CM and age PM policies for a linear consecutive-5-out-of-6: F system with component failure rate $\lambda = 0.01$ and $c_{PM} = 1$. We can know from Table 6 that the proposed policy outperforms CM and age PM policies. When the cost c_{CM} increases, the proposed policy is more suitable and can reduce the expected cost rate much more. The replacement cost c_R gives the opposite effects, where the higher c_R will bring less improvement percentage values.

Table 6: Expected cost rates for various cost parameters (CM and age PM)

$\frac{c_{CM}}{c_{PM}}$	c_R	Corrective replacement				Age replacement				
		$E[N]$	$E[T]$	EC_{CM}	$IP_{Cr,CM}$	$E[N]$	$E[T]$	EC_A	T_A^*	$IP_{Cr,A}$
2	0.01	5.7	211.67	0.010	6.59	5.5	199.37	0.010	346.2	6.59
	0.05	5.7	211.67	0.011	1.89	5.7	211.67	0.011	∞	1.89
	0.1	5.7	211.67	0.012	0.00	5.7	211.67	0.012	∞	0.00
	0.5	5.7	211.67	0.023	88.43	5.7	211.67	0.012	∞	0.00
3	0.01	5.7	211.67	0.014	58.24	4.5	129.77	0.013	142.8	41.76
	0.05	5.7	211.67	0.016	46.23	4.6	135.31	0.014	151.1	34.91
	0.1	5.7	211.67	0.017	35.20	4.7	143.09	0.016	163.6	28.00
	0.5	5.7	211.67	0.028	0.00	5.7	211.67	0.028	∞	0.00
4	0.01	5.7	211.67	0.019	110.99	4.0	106.55	0.015	111.9	63.74
	0.05	5.7	211.67	0.020	90.57	4.1	109.62	0.016	115.7	54.72
	0.1	5.7	211.67	0.022	72.80	4.2	113.73	0.018	120.9	46.40
	0.5	5.7	211.67	0.032	16.19	5.1	163.94	0.032	204.2	14.75
5	0.01	5.7	211.67	0.024	162.64	3.7	93.95	0.017	97	81.32
	0.05	5.7	211.67	0.025	135.85	3.8	96.04	0.018	99.4	69.81
	0.1	5.7	211.67	0.026	110.40	3.8	98.87	0.020	102.7	60.00
	0.5	5.7	211.67	0.037	33.09	4.5	127.91	0.035	140.1	24.82
6	0.01	5.7	211.67	0.029	214.29	3.5	85.78	0.018	87.8	94.51
	0.05	5.7	211.67	0.030	180.19	3.5	87.40	0.019	89.6	82.08
	0.1	5.7	211.67	0.031	148.00	3.6	89.46	0.021	91.9	70.40
	0.5	5.7	211.67	0.042	50.00	4.1	110.02	0.037	116.2	32.37
7	0.01	5.7	211.67	0.033	265.93	3.3	79.94	0.019	81.4	105.49
	0.05	5.7	211.67	0.034	224.53	3.4	81.23	0.020	82.8	92.45
	0.1	5.7	211.67	0.036	185.60	3.4	82.87	0.023	84.6	80.00
	0.5	5.7	211.67	0.047	67.27	3.8	98.79	0.039	102.6	38.49
8	0.01	5.7	211.67	0.038	318.68	3.2	75.48	0.020	76.6	115.38
	0.05	5.7	211.67	0.039	268.87	3.2	76.50	0.021	77.7	100.94
	0.1	5.7	211.67	0.041	224.00	3.3	77.90	0.023	79.2	87.20
	0.5	5.7	211.67	0.051	84.17	3.6	90.97	0.040	93.6	43.17

5. Conclusion

In this paper, we considered a maintenance problem for a linear consecutive- k -out-of- n : F system. A condition-based maintenance policy is used to minimize the expected cost rate under assumption that we can monitor the system continuously and can know the component state at any time. If there is one minimal cut set consisting of one working component, the system will be maintained after a certain PM interval T_{PM} . We considered that the failed components are replaced at maintenance time. The expected cost rate model is derived

based on system failure paths and the time interval T_{PM}^* is optimized by minimizing the expected cost rate. Numerical examples are studied to show the effects of the system and cost parameters to the optimal T_{PM}^* . When the component failure rate λ increases, the optimal time interval T_{PM}^* becomes smaller, but when the system size n increases, the optimal time interval T_{PM}^* becomes larger. When the cost of CM increases, the optimal time interval T_{PM}^* becomes shorter. The expected cost rates from CM, age PM, and CBM policies are compared and values of improvement percentage (IP) are calculated to show the cost reduction. In general, condition-based maintenance policy outperforms CM and age PM policies because the IP values are positive (the expected cost rates from CBM policy are less than the expected cost rates from CM and age PM policies).

For further study, an inspection policy can be considered to know the component state when we cannot monitor the system and component state continuously. Also, a maintenance problem with finite number of spare components can be considered and which failed components should be replaced first is obtained.

Acknowledgement

This research was supported by Basic Science Research Program through the National Research Foundation of Korea (NRF) funded by the Ministry of Education, Science and Technology (NRF-2013R1A1A2060066).

References

- [1] R.E. Barlow and L.C. Hunter: Optimum preventive maintenance policies. *Operations Research*, **8** (1960), 90–100.
- [2] R.C. Bollinger and A.A. Salvia: Consecutive- k -out-of- n : F system with sequential failures. *IEEE Transactions on Reliability*, **R-34** (1985), 43–45.
- [3] E.R. Canfield and W.P. McCormick: Asymptotic reliability of consecutive- k -out-of- n systems. *Journal of Applied Probability*, **29** (1992), 142–155.
- [4] A.J. Endharta and W.Y. Yun: Condition-based maintenance policy for linear consecutive- k -out-of- n : F System. *Communication in Statistics–Simulation and Computation*. doi:10.1080/03610918.2015.1073305.
- [5] J. Flynn and C.S. Chung: A heuristic algorithm for determining replacement policies in consecutive- k -out-of- n systems. *Computers and Operations Research*, **31** (2004), 1335–1348.
- [6] J.M. Kontoleon: Reliability determination of r -successive-out-of- n : F system. *IEEE Transactions on Reliability*, **R-29** (1980), 600–602.
- [7] W. Kuo and M.J. Zuo: *Optimal Reliability Modeling* (John Wiley and Sons, Inc, Canada, 2003).
- [8] M. Lambiris and S. Papastavridis: Exact reliability formulas for linear and circular consecutive- k -out-of- n : F systems. *IEEE Transactions on Reliability*, **R-34** (1985), 124–126.
- [9] E.A. Pekoz and S.M. Ross: A simple derivation of exact reliability formulas for linear and circular consecutive k -out-of- n : F systems. *Journal of Applied Probability*, **32** (1995), 554–557.
- [10] W.Y. Yun and A.J. Endharta: A preventive replacement policy based on system critical condition. *Proceedings of the Institution of Mechanical Engineers, Part O: Journal of Risk and Reliability*, **230(1)** (2016), 93–100.

- [11] W.Y. Yun, G.R. Kim, and H. Yamamoto: Economic design of a circular consecutive- k -out-of- n : F system with $(k-1)$ -step Markov dependence. *Reliability Engineering and System Safety*, **92** (2007), 464–478.
- [12] W.Y. Yun, G.R. Kim, and H. Yamamoto: Economic design of a load-sharing consecutive- k -out-of- n : F system. *IIE Transactions*, **44** (2012), 55–67.
- [13] M. Zuo and Y. Wu: Reliability evaluation of a furnace system using the k -out-of- n and the consecutive- k -out-of- n reliability models. *Proceedings of the IEEE International Conference on Systems, Man, and Cybernetics Beijing*, **R-34** (1996), 3119–3123.

Won Young Yun
Department of Industrial Engineering
Pusan National University
Geumjeong-gu Jangjeon-dong
Busan 609-735, Korea
E-mail: wonyun@pusan.ac.kr